

LAP-2.V2

ANALOG LINEAR-PREAMPLIFIER



The LAP-2.V2 is an ultralinear preamplifier for the small studio as well as for the High-End user with sound neutrality in mind. The unit is the successor of the well established LAP-2 with a new developed input matrix, a further optimized signal path and a second output for connecting a subwoofer. The 6 stereo inputs are for incoming analogue signals e.g. CD, CD-R, MiniDisc, DAT, DAB-receiver, tape recorder, cassette recorder, phono preamplifier, FM tuner, Hard-Disc recording system, audio mixing desk and

additional analogue audio sources.

The preamplifier was developed from our professional reference monitor systems for mastering studios and with its excellent sound characteristics sets a new highlight in its class. Highly advanced amplifier technology for every input secures lowest load for the audio signal.

Since the appearance of the predecessor of the LAP-2.V2 test magazines used the unit as a neutral reference in preamplifier tests.



the **LAP-2.V2** offers the following functions:

1. **RECORD**-selection for up to 6 analog stereo sources
2. **MONITOR**-selection for up to 6 analog stereo sources
3. RECORD-distribution 1 to 4
4. Level adjustment for different equipment outputs
5. Impedance conversion from high to low
6. High quality headphone amplifier
7. „Power-Down“-mute relays at the monitor outputs
8. Storage of the selected input configuration after “power off”

All 6 inputs are unbalanced via RCA-jacks and furnished with gold plated contacts. Independently of the selected input signal one of the 6 signal sources can be used for recording purposes (record router). This recording signal is simultaneously available at all 4 stereo outputs. Every input is switchable to every output.

The LAP-2.V2 with calibration trimmer access (option) allows the user to adjust each channel of the 6 stereo inputs to different signal levels. The audio matrix operates without any mechanical contacts to achieve high reliability, long life and consistency of the audio parameters.

The LAP-2.V2 can operate as an independent preamplifier with active speakers as well as with power amplifiers (**LAP-2.V2 a**) or as an extension for existing preamplifiers (**LAP-2.V2 b**).

More than 130 dB dynamic, excellent frequency and phase response (less than 1 Hz to over 500 kHz) as well as lowest nonlinear distortions of typical < 0,0001% (-120 dB) in the important midrange are unique and allow a true evaluation of the selected signal source.

All analogue input signals are processed to the active matrix over highest input impedance amplifiers. This circuit

eliminates low frequency phase distortion from the transmitting unit. Because of the achieved parameters weakest audio signals will be amplified without sound colouration. The buffer technology is a precondition for highest channel separation between the inputs specially at high audio frequencies of 10 kHz with more than 100 dB (1 kHz more than 110 dB).

Every input is directly selectable. Through that different signal sources can be compared almost without any delay while switching between sources. With unmodulated sources the electronic input selection is clickfree.

In spite of the extremely low input noise signal sources of very high levels up to 24 dBu used in the professional field will be accurately processed. The low impedance output stages of the LAP-2.V2 are responsible for a low loss signal transfer of all monitor and record signals.

RECORDING :

With the record router a signal for copying can be selected independently of the selected monitor source. The record signal is available of all 4 record outputs and allows analog copies to different equipment simultaneously without the use of a Y-cable or jackfield.

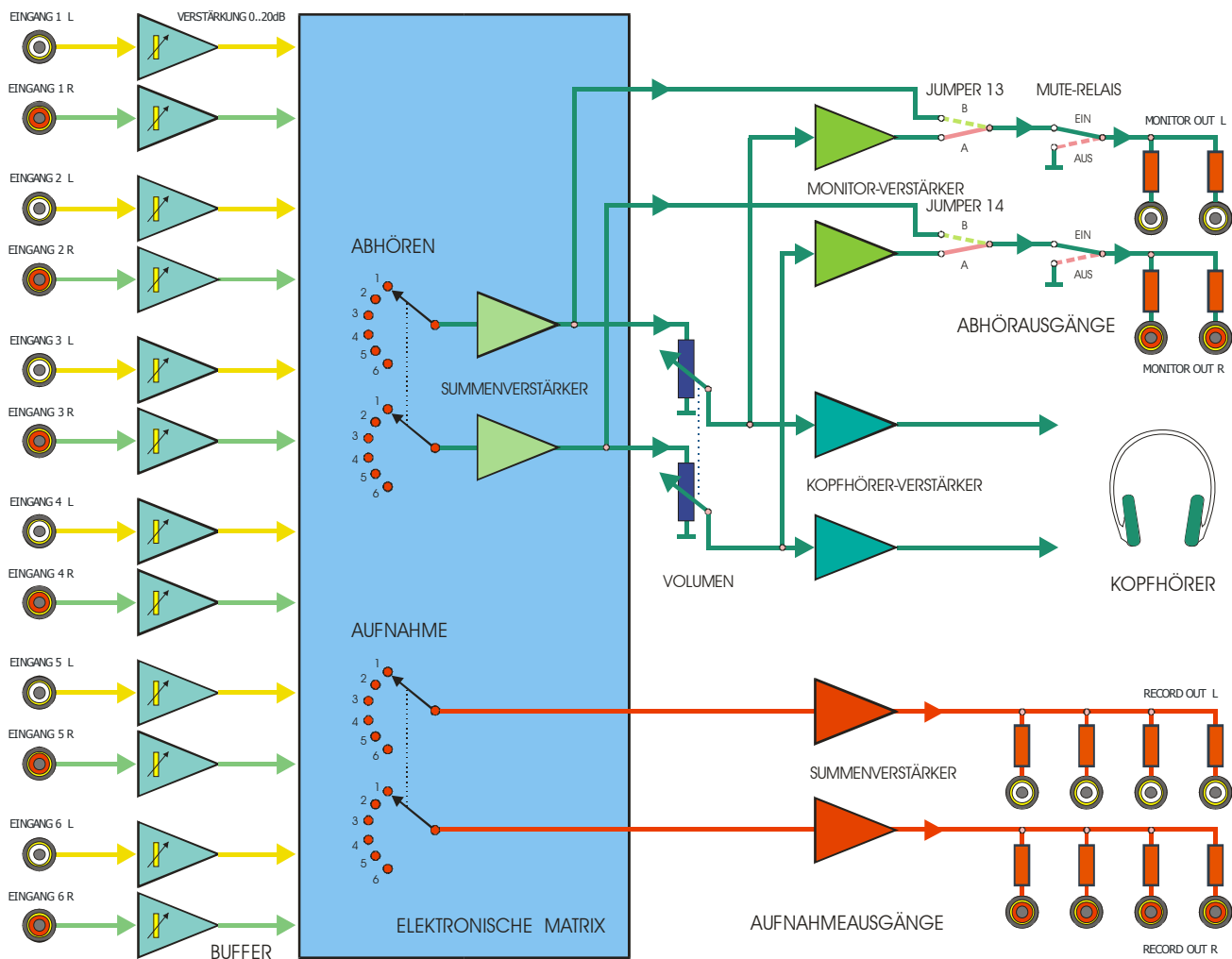

The LAP-2.V2 with the calibration trimmer access for fast level adjustment is available as an option (small lid within the topcover secured by 4 screws).

The 4mm aluminium front is available in different colours. Possibilities are as follows: white paint (RAL7035), anodized in black, blue, darkred, silver and gold colour. Optional massive polished brass with real goldlayer or chromeplated.

In the standard version the volume control of the LAP-2.V2a adjusts headphone and monitor outputs together.

For special purposes the unit is also available with fixed

monitor outputs similar to the record output (LAP-2.V2 b). In this version the volume control operates the headphone amplifier only.

Special version: LAP-2.V2 MR with simultaneously selection of monitor and record outputs (option). The selected monitor signal controlled by the volume control is available at the monitor outputs and at the same time at the record outputs with a fixed and independent level. On these outputs the level of the selected signal source can be monitored by a level meter, vectorscope or routed to additional equipment.



Rearpanel

Excerpt from the datasheet :

Frequeny response :	1 Hz...200 kHz < ± 0,5 dB	10 Hz ...20 kHz < ± 0,01 dB
Phase response :	20 Hz ...20 kHz ± 2° absolute	20 Hz ...20 kHz ± 0,5° relative
Nonlinear distortion (THD) 1 kHz :	< 0,00015 % typ. < 0,0001 % at +6 dBu input level	
Nonlinear distortion + noise (THD+N) :	1 kHz < 0,0003 % (20 Hz...20 kHz)	10 kHz < 0,0007 %
Crosstalk input/input :	1 kHz > 112 dB	10 kHz > 103 dB
Noise MONITOR-OUT unweighed :	-108,0 dBu 20 Hz...20 kHz eff. (Gain = 0,0 dB)	
Dynamik MONITOR OUT (S/N) :	136 dB A-weighted eff. (Gain = 0,0 dB)	132 dB CCIR 468 unweighted
Dimension :	210mm x 172mm x 42mm	