

PWS-08MP-T.V2

Precision power supply
Extremely low noise

NEW

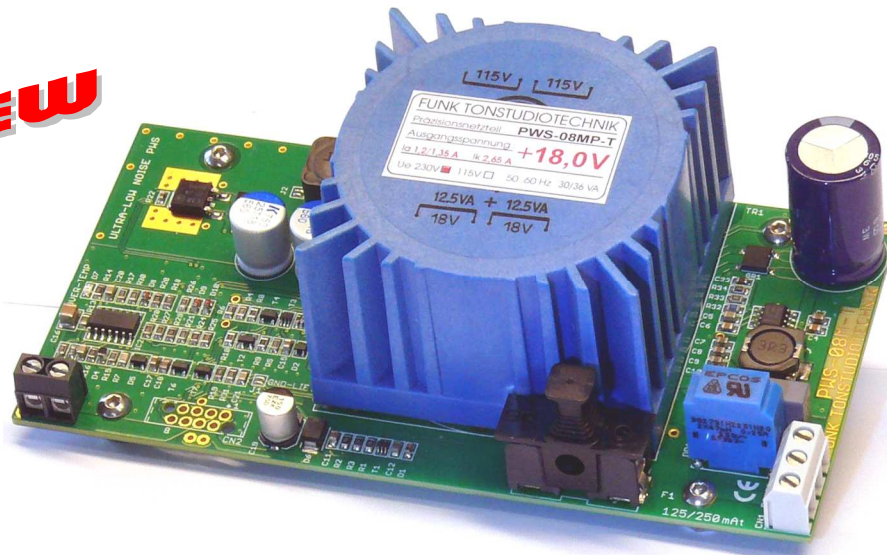

DESCRIPTION:

Application: The **PWS-08MP-T.V2** is mainly intended for powering sensitive analogue/digital audio circuits such as DA converters or purely analogue audio circuits as well as computer circuits in the small to medium power range. The PWS-08MP-T.V2 is especially useful for direct supply of the connected analogue or digital circuits without any further intermediate stabilisation on the board to be supplied. Today, many DA converters for audio applications work with supply voltages between 3.3...6 volts, rarely also with 12 V or higher voltages. The power supply unit is therefore mainly designed for use with relatively low supply voltages, but delivers a higher output current. The available output voltages start at 3.3 volts and go up to 18 volts.

The PWS-08MP-T.V2 is a more powerful version of the PWS-05M-T/PWS-08M-T series. It provides a fixed output voltage. A changeover by the user is not provided. The available output power depends on the output voltage and is between 15 and 22 watts.

Problem situation: For very low supply voltages, the efficiency of previous purely linear power supply units is relatively low. Very high capacitances are also required for the charging capacitors in order to ensure sufficient current in the 100 Hz charging pauses at higher power through the rectified mains frequency. For this reason, the new PWS-08M-T is based on a different principle.

Construction principle PWS-08MP-T.V2: By combining a 50..60 Hz mains transformer, a subsequent switching stage in combination with a linear output stage, a significantly better efficiency is achieved.

The switching stage takes over the lion's share of the filtering of the mains frequency. In addition, it generates the voltage reduction for the optimal supply of the linear power output stage. As a result, there is only little power loss in normal operation and thus less heating of the power supply unit. A heat sink can be omitted. In addition, strong fluctuations of the mains voltage are almost completely compensated for in this switching power supply stage. In addition, depending on the output voltage, interference voltages of less than 5 μV , typ. 3...5 μV at a measuring bandwidth of 10 Hz...20 kHz are realised by this principle. Common power supplies often generate a 10...100 times higher interference voltage at the output

Voltage precision: The accuracy of the output voltage to the specified nominal value is better than 0.1 % at all permissible loads, typically <0.05 % ! The output voltage precision at a change of the mains voltage of $\pm 5\%$ is clearly less than 0.001% and is thus in the range of professional laboratory power supplies.

Protection: The power supply unit is equipped with an integrated toroidal transformer and several protective functions to ensure safe operation in all cases. Electronic current limiting, short-circuit current reduction and 2 thermal protection circuits are integrated. In the event of an imminent thermal overload, for example due to insufficient cooling caused by improper installation, the power supply unit switches down the output current and indicates this thermal shutdown by means of an LED on the circuit board. After the overload has been eliminated, the power supply unit is immediately ready for operation again, provided that the overtemperature protection is no longer active. It automatically returns to normal mode. Both the switching and filter stages as well as the analogue output circuit have independent protective circuits. This extensive electronic protection means that even in the event of a short circuit, the fuse in the primary circuit will not blow. It is therefore not necessary to change fuses. The power supply unit is permanently short-circuit proof

Mute relay (time switch): the power supply unit has a time-controlled output, e.g. for supplying a muting relay. This output provides a control voltage for a relay approx. 6 seconds after the power supply unit is switched on. If the power supply unit is switched off, this output is switched off before the main output voltage drops. The same applies if the protective circuit of the power supply unit is activated. After cooling down and removal of the overload, the control voltage is also available again with a time delay after typ. 6 sec. This "power-down-mute" circuitry largely avoids "switch-on crackles" when switching a sound system on and off, or eliminates already existing switch-on noises. This control voltage is applied to the 8-pin redfit IDC connector between pin 7 (+) and 8 (0 volt) and should be loaded with a maximum of 20 mA. Depending on the load of the power supply unit, this control voltage is between typ. 21...30 volts.

Power-On-LED:

for monitoring purposes, a control LED can be connected between pin 5 (+) and pin 6 (0 volt). The voltage of this output corresponds to the internal constant supply voltage of approx. 6.8 volts at connection pin 5. A series resistor with 4.99 k Ω for an LED is already integrated on the board for pin 5.

Power-over-LED:

the red LED D7 on the board (power over) indicates thermal protection activated by overtemperature. This can be caused by an excessively high operating temperature of the mains transformer or the output transistor.

Mains connection:

the mains voltage reaches the circuit board via screw terminals and can be between 210...260 V. A primary fuse, 250 mA slow-blow, for the mains voltage is already on the circuit board. For supply voltages between 105...130 V /60 Hz, the power supply unit can be converted on the underside by repositioning solder jumpers and replacing the primary fuse with a type with 500 mA. The unit is already equipped with a mains filter for the 230/115 V supply and consists on the primary side of a common-mode choke with 2x 47 μ H and a X-capacitor 0.1 μ F behind.

Connection main outputs:

the output voltages are available at the 8-pole Redfit IDC connector and additionally at 2 screw terminals.

In the PWS-08MP-T.V2, circuit zero (0V) is connected to the chassis via an RC element and solder jumper 1. The RC element consists of a parallel connection of a 330 Ω resistor and a 47 nF capacitor. By opening jumper 1, this connection can be disconnected and the output voltage becomes "floating", i.e. it no longer has a reference to the chassis.

Dimensions : 140.0 mm x 72 mm x 45 mm (length x width x height), weight: 0.52 kg

Printed circuit board PWS-08MP-T.V2 Top view with 230V/115V mains tracks
(red are upper and blue are lower traces)

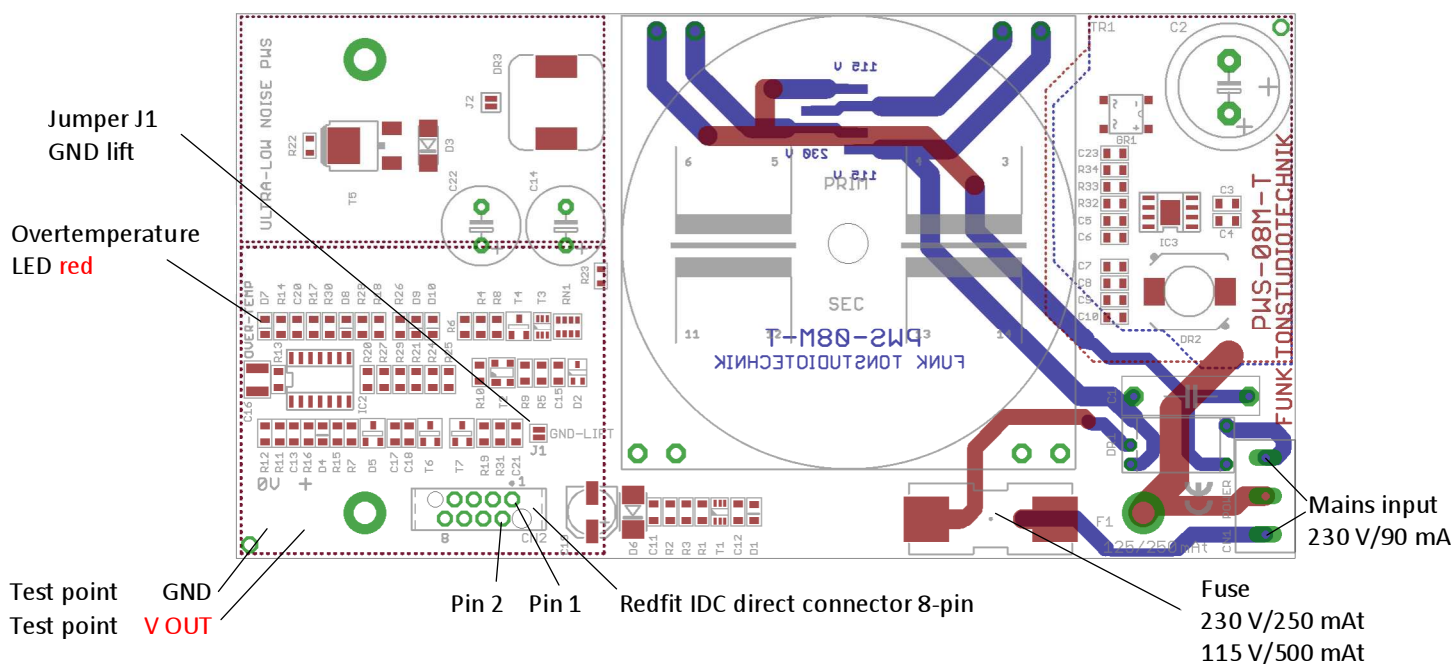

CONNECTION CN2 8-pin. Redfit IDC connector :

- Pin 1 +3,3 V...+18 V
- Pin 2 +3,3 V...+18 V
- Pin 3 0 Volt
- Pin 4 0 Volt
- Pin 5 +6,8V Power-On-LED, (Ri= 4,99 k Ω)
- Pin 6 0 Volt Power-On-LED
- Pin 7 +21...+30 V Mute- Relay
- Pin 8 0 Volt Mute- Relay

CONNECTION CN1 3-pole. SCREW CONNECTOR :

- Pin 1 ~ 230 V /50..60 Hz
- Pin 2 Chassis (Erde/Ground)
- Pin 3 ~ 230 V /50..60 Hz

Available output voltages :

measured at 230 V and 50 Hz supply voltage. I_{short} = Current permissible for max. 5 minutes.

1x 3,3 V	0 mA	I_{short} 0 mA	I_k typ. 0 mA (under development)
1x 5,0 V	3000 mA	I_{short} 3400 mA	I_k typ. 3700 mA
1x 6,0 V	0 mA	I_{short} 0 mA	I_k typ. 0 mA..(under development)
1x 6,3 V	0 mA	I_{short} 0 mA	I_k typ. 0 mA (under development)
1x 7,5 V	0 mA	I_{short} 0 mA	I_k typ. 0 mA..(under development)
1x 9,0 V	2200 mA	I_{short} 2400 mA	I_k typ. 3000 mA
1x 12 V	1700 mA	I_{short} 1900 mA	I_k typ. 2150 mA
1x 15 V	1450 mA	I_{short} 1600 mA	I_k typ. 2200 mA
1x 18 V	1200 mA	I_{short} 1350 mA	I_k typ. 1450 mA

Mounting: the power supply unit is mounted at a distance of 5 mm from the chassis. 4 internal threaded metal spacer bolts M3 are already integrated for this purpose. Threaded bolts in other lengths are also available. For safety reasons, a thin insulating plate should be provided under the PWS-08MP-T.V2 if the mounting base is electrically conductiv!

Illustrations approximately in original size

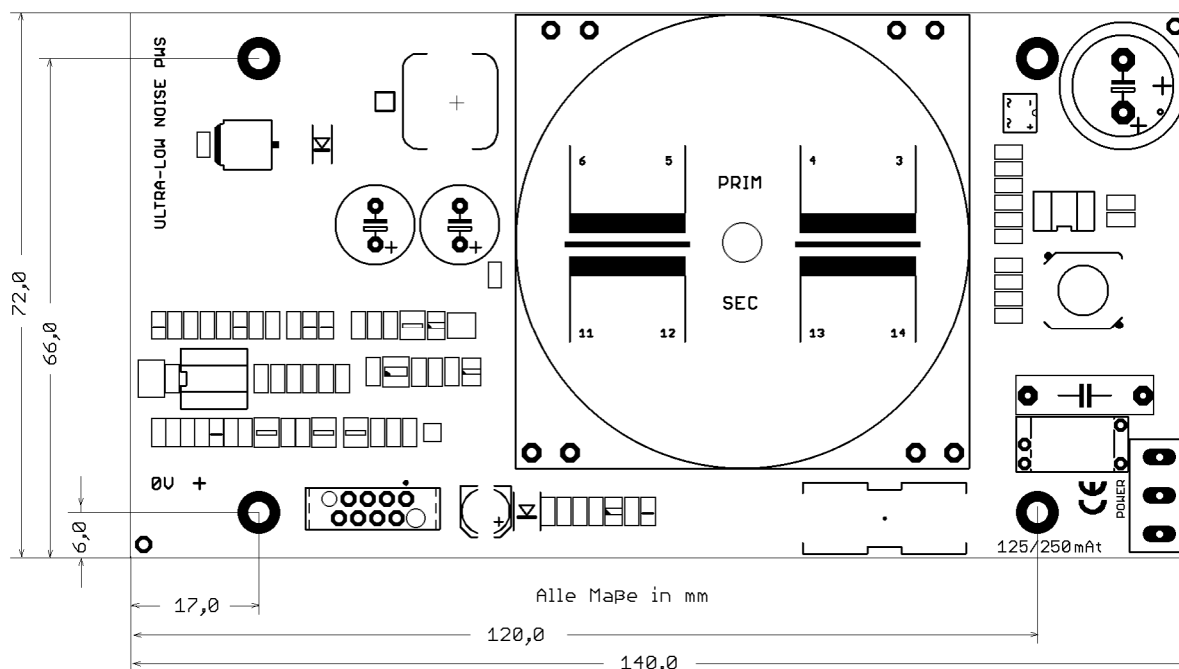

Mains voltage switchover: The power supply unit is set to 230V/50 Hz alternating voltage as standard. If required, operation on 115V/50..60 Hz is also possible. Conversion to 115V/50..60 Hz can be done by disconnecting the 230V solder jumper and setting 2 adjacent 115V jumpers. These jumpers are located on the underside of the unit.

ATTENTION : this changeover must never be made with the mains voltage connected!

When operating on 115V power supply networks, the primary fuse of 250 mA, 5x20 mm must be replaced with a type 500 mA.

Bottom view of circuit board (mains supply only) Jumper for mains voltage

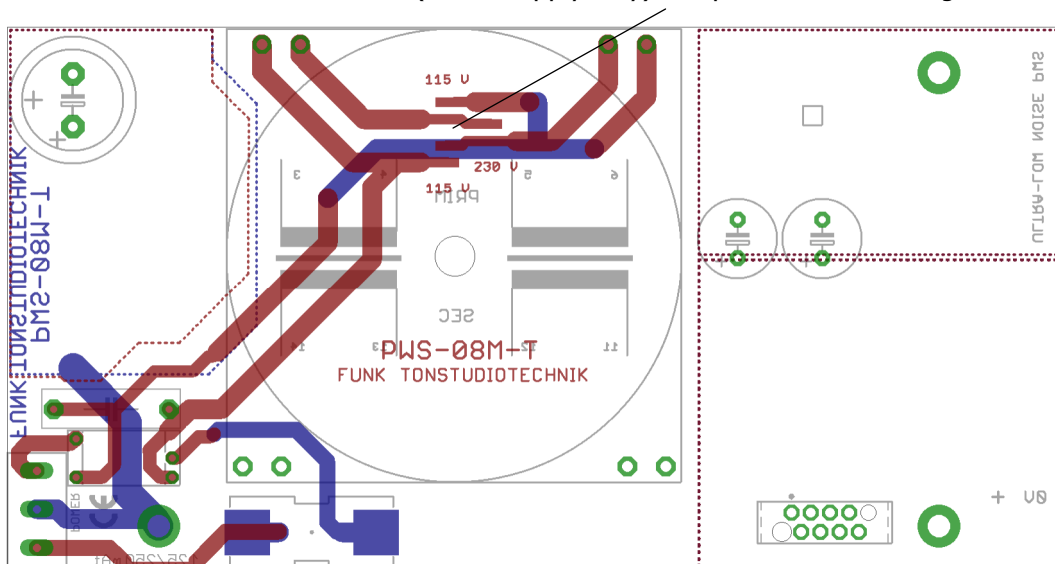

Noise voltage at the outputs of the PWS-08MP-T.V2:

The following two measurement diagrams show spectral analyses of the output voltages, exemplified by the power supply unit PWS-08MP-T with +12.0 V output voltage. The upper measurement record shows the exceptionally low interference voltage on the output voltage in μV or nanovolts in the range 10 Hz..1 MHz at a nominal power of 1,0A. The lower measurement record shows a similar measurement, but this time with an output current of 1 A. The largest interference frequencies here have a level of typ. $< 0.2 \mu\text{V}$ or 200 nV! (which corresponds to $< 0.000002 \text{ V}$). The frequency resolution of the measurement lines in the diagrams is still below 1 Hz.

The left scale in both diagrams shows the level of the interference voltage calibrated in μV or nV. The lower scale shows the corresponding frequency. The effective interference voltages are only about 1/10...1/50 of otherwise usual laboratory power supplies. Therefore, the PWS-08M-T can replace many battery power supplies in terms of the cleanliness of the generated output voltage. The distance of the effective interference voltage at the output in the range 10 Hz...22 kHz to the output DC voltage is approx. 3.5...4 μV at typ. -130 dB, independent of the power just drawn. The highest interference peaks in the spectrum are typically 142 dB below the respective supply voltage.

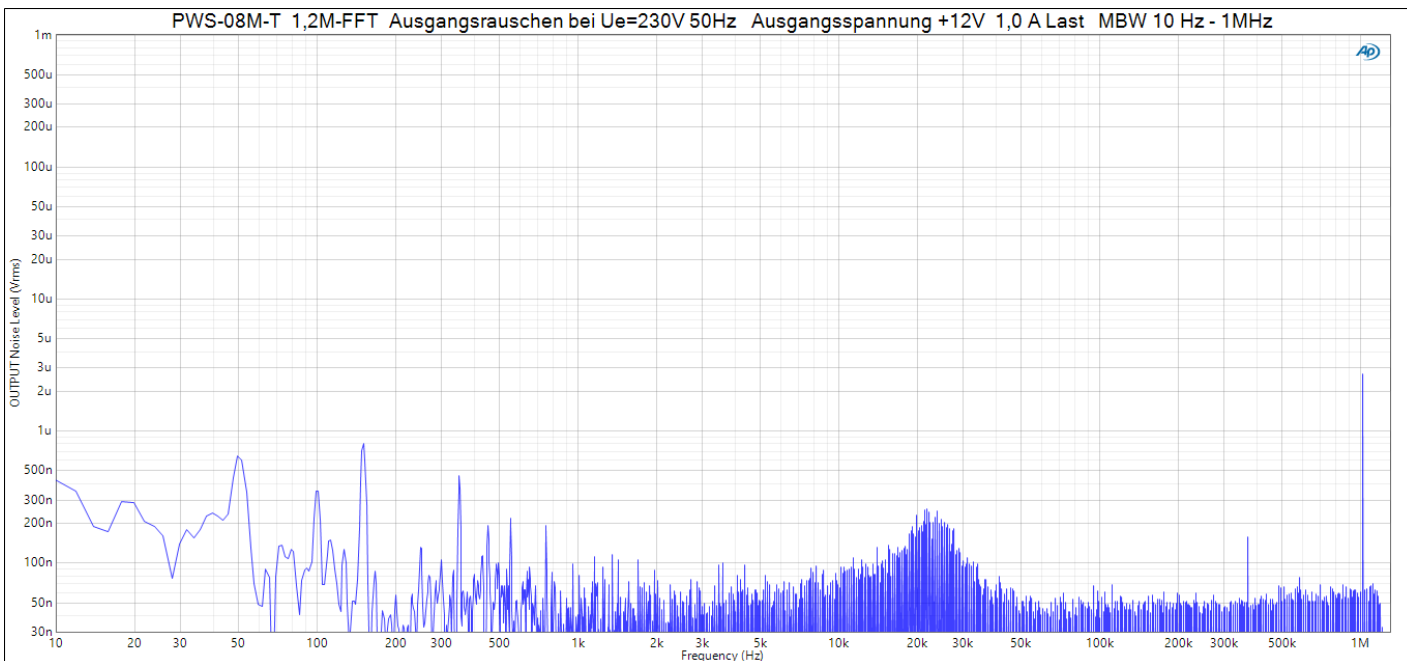

This measurement record shows the course of the interference spectrum in the range of 10 Hz...1 MHz at a continuous load of 1.0 A. The highest lines in the spectrum are approx. 0.8 μV . The resolution of this measurement results in a bandwidth of approx. 0.9 Hz per individual measuring point with 1,200,000 measuring points over the measured frequency range of 1 MHz. The total effective interference voltage measured here from 10 Hz...1 MHz is typically only 12 μV ! Even professional laboratory power supplies have 10...50 times the noise values here !

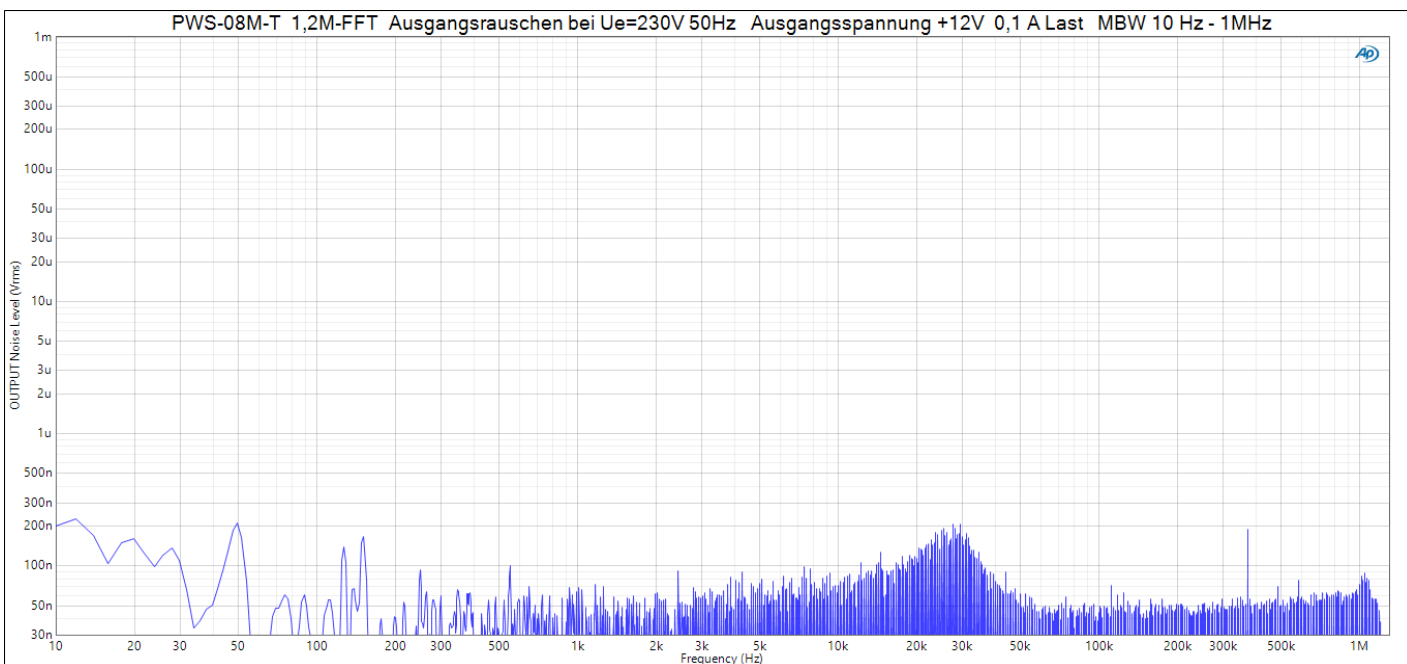

Power supply loaded with 100 mA. The highest lines in the spectrum are approx. 0.2 μV and 200 nV. The resolution of this measurement results in a bandwidth of approx. 0.9 Hz per individual measuring point with 1,200,000 measuring points over the measured frequency range of 1 MHz. The total effective interference voltage in the range of 10 Hz...1 MHz in this case is typically $< 10 \mu\text{V}$.